

PRODUCT DATA SHEET

DURO-LAST® TAB SEALER 4725

Description:

Duro-Last Tab Sealer 4725 is a solvent-based contact-bonding agent that is designed for use with the Duro-Last Duro-Roof™ system. Tab Sealer 4725 is highly volatile and gives off vapors that can be ignited by common ignition sources. This bonding agent should only be used in well-ventilated areas away from common ignition sources. See MSDS for additional information. Empty containers should be treated with the same caution. Duro-Last Tab Sealer 4725 is available in three-gallon pails. In planning work, consider weather-related conditions such as frost, mist, dew, condensation, humidity, and temperature. Temperature should be above 40° F and more than 5° F above the dew point and rising, long enough for initial curing to occur. Precipitation should not be imminent.

Application Installation:

Stir the product prior to use. Prepare the membrane surfaces to be bonded by making sure they are clean, dry and free from any contaminants. Duro-Last Tab Sealer 4725 should be applied with a solvent-resistant 9-inch medium-nap paint roller, in smooth, even coats with no puddles or globs. **DO NOT LEAVE CONTAINER OPEN FOR MORE THAN 20 MINUTES. THIS IS YOUR OPEN TIME - DO NOT EXCEED THE OPEN TIME.**

First, install fasteners into the six-inch fastening tab (3-inch square metal plate or liquid auger only).

- 1) Apply Tab Sealer 4725 on or over the six-inch fastening tab at the rate of one gallon per 60 linear feet.
- 2) Apply Tab Sealer 4725 on or over the underside of the Duro-Last membrane next to each factory weld at the same application rate.
- 3) The membrane should be carefully unfolded onto the substrate to position each successive six-inch fastening tab. Take caution to avoid wrinkles or air pockets, while Tab Sealer 4725 is flashing off the membrane. Do not wait more than the recommended open time of 20 minutes.
- 4) The bonded fastening tab should be firmly pressed into place with a stiff push broom or a weighted roller on the topside surface to ensure full, smooth contact smooth finish to the underside of the membrane.

Note: Tab Sealer 4725 coverage and bonding strength can be affected by environmental conditions. The ambient air temperature, membrane temperature and the temperature of Tab Sealer 4725 itself must be maintained at 40° F or higher and rising before installation proceeds. Protect product from freezing. Store product between 50° F and 70° F for maximum shelf life. Do not store below 40° F. Shelf life is one year in unopened container when following these recommended storage procedures.

For more information on these and other Duro-Last Products, contact the Duro-Last Engineering Services Department.

E-Mail: engineering@duro-last.com

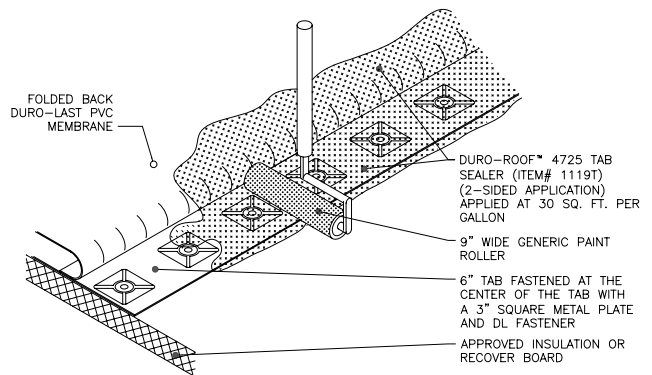

For more information on these and other Duro-Last Products, contact the Duro-Last Engineering Services Department.

E-Mail: engineering@duro-last.com

