

PRODUCT DATA SHEET

DURO-LAST LIQUID AUGER

Description:

The Liquid Auger fastener is a composite nylon and fiberglass screw that has a 3-inch diameter head (stress plate) with an internal hex head drive. The stress plate is part of the design for easy installation. The fastener can be installed with a 9/16-inch hex-head screw gun adapter bit that is supplied with each order. Liquid Auger fasteners are designed to attach insulation and roofing membrane to lightweight concrete, cementitious wood fiber, and gypsum decks. If you need an enhanced pull value, the fastener has a hollow shaft through which epoxy Pliogrip 7779L/220 (220 ml) may be injected using a Dual Cartridge caulk gun, item #1189. The fluid flows down through the shank and out the disbursement outlets into the surrounding substrate where it hardens. When installed on cementitious wood fiber, Pliogrip will fill approximately 20 fasteners. On all other decks, it will fill approximately 40 fasteners. The Liquid Auger exceeds FM 4470 specifications.

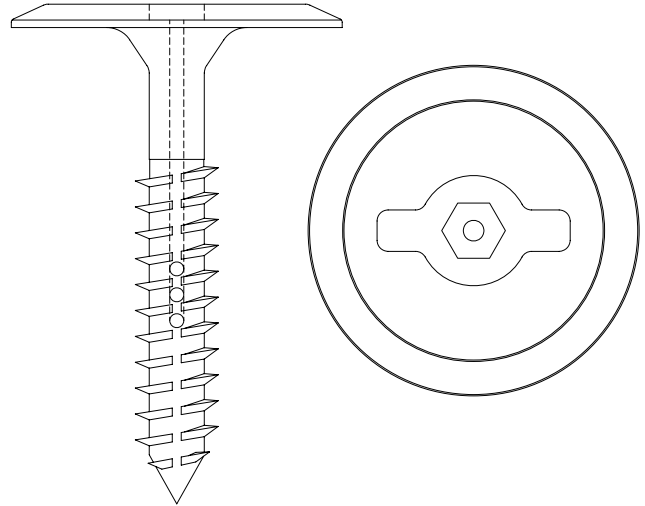

Duro-Last stocks Liquid Augers in the sizes shown below. The fastener length range is 3-inches (76 mm) to 7-inches (178 mm), in ½-inch (13 mm) increments.

Installation:

The Liquid Auger fastener is designed for use with the Duro-Last roofing system. A 7/16" - 9/16" pilot hole is required on gypsum and lightweight concrete decks depending on density of the deck. No pilot hole is required on cementitious wood fiber decks, unless a re-roof application exists where breaking through an existing roof such as BUR or other bituminous asphalt roofs is required. The fastener must penetrate into the deck a minimum of 2-inches. For maximum pullout resistance on cementitious wood fiber, inject 10cc (about 2 pumps from the caulk gun) of Pliogrip® 7779L/220 into the injection inlet of the Liquid Auger fastener.

Note:

Use extreme care NOT to penetrate completely through the deck with either the pilot drill or the screw. In doing so, you void the warranty.

Size	Amount/box
3.0" 76 mm	500
3.5" 89 mm	500
4.0" 102 mm	500
4.5" 114 mm	500
5.0" 127 mm	500
5.5" 140 mm	250
6.0" 152 mm	250
6.5" 165 mm	250
7.0" 178 mm	250

For more information on these and other Duro-Last Products, contact the Duro-Last Engineering Services Department.

E-Mail: engineering@duro-last.com

"Duro-Last" and the interlocking "DL" are registered marks owned by Duro-Last Roofing, Inc. October 2005



Duro-Last Roofing, Inc.
525 Morley Drive
Saginaw, MI 48601
Ph: 1-800-248-0280
Fax: 1-800-432-9331
www.duro-last.com