

PRODUCT DATA SHEET

DURO-LAST COMPOSITE DRAIN RINGS

Description:

Duro-Last® Composite Drain Rings, or “CDRs”, are manufactured from a state of the art epoxy-fiberglass composite. The rings are shipped tied together with a cord approximately 12-inches (305 mm) long. Their purpose is to provide a positive seal between the Duro-Last® Drain Boot and the drain pipe.

Installation:

Insert the first drain ring as low into the installed drain boot as possible, 6-inch minimum depth, and cut compression cord. Install the second ring in a like manner with the opening on the opposite side to the opening on the installed ring. Cut compression ring cord and allow ring to expand. Sealant and expandable CDRs are to be located at the same depth within the drain (See detail 2020).

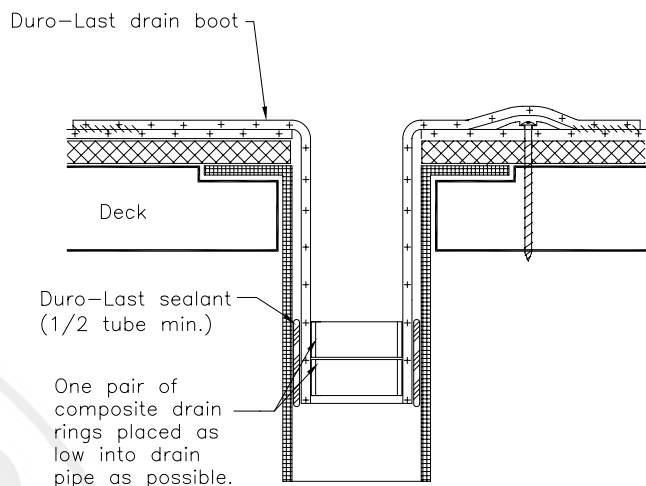
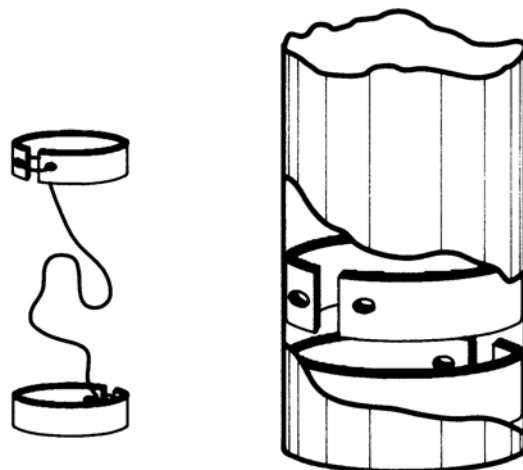

For more information on these and other Duro-Last Products, contact the Duro-Last Engineering Services Department.

E-Mail: engineering@duro-last.com

“Duro-Last” and the interlocking “DL” are registered marks owned by Duro-Last Roofing, Inc. October 2005



Duro-Last Roofing, Inc.
525 Morley Drive
Saginaw, MI 48601
Ph: 1-800-248-0280
Fax: 1-800-432-9331
www.duro-last.com